

Rückseite des Steckers
mit Terostat-92 abdichten
Plugging the rear side of
the connector with Terostat-92



28980068



1

Schirmring wird nicht benötigt (Lieferumfang 19730621)
Shielding ring is not required (supplied 19730621)

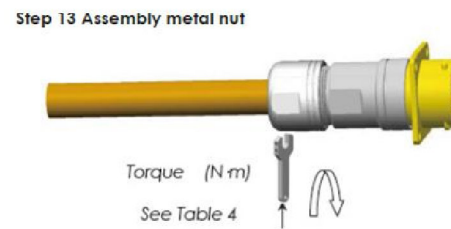
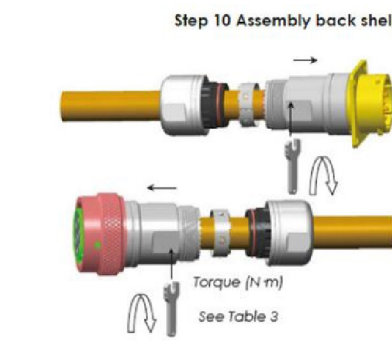
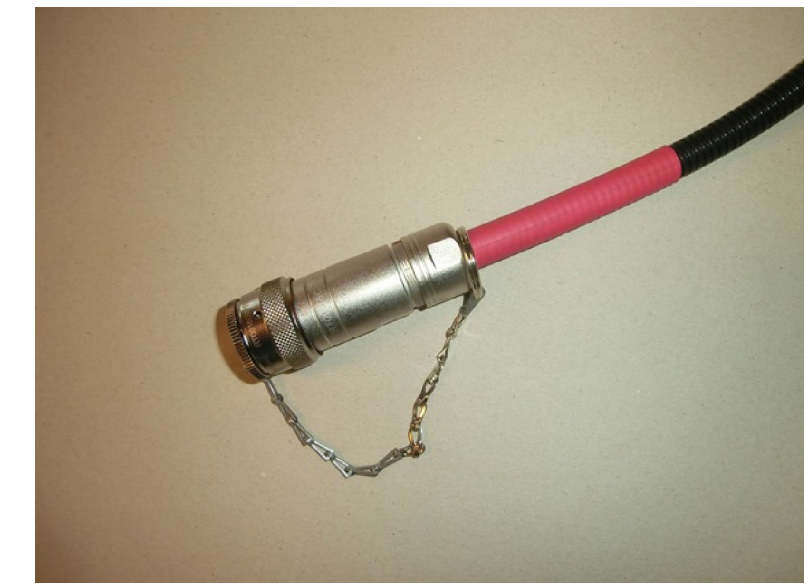

Table 3		Table 4	
Size	Torque=T1 (N.m)	Size	Torque=T2 (N.m)
10	1.5-2.5 N.m	10	2.0-3.0 N.m
12	2.5-4.0 N.m	12	3.0-5.0 N.m
14	2.5-4.0 N.m	14	3.5-5.5 N.m
16	3.0-4.5 N.m	16	4.0-6.0 N.m
18	3.0-4.5 N.m	18	5.0-8.0 N.m



Schrumpfschlauch als Markierung über das Ende
des Wellenschlauches schrumpfen (bündig abschliessend)

Shrink heat tube for marking
over the end of the corrugated tube (to be flush with)

Kette der Schutzkappe mit Schlüsselring verbinden
Connect chain of the protection cap with key ring

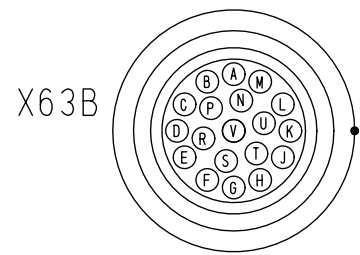

19730621
19730639
19730613

A					
B					
C					
D					
E	0.75	A1503	5	WH	
F	1.0	A3210	10	WH	
G	1.0	A3210	11	WH	
H					
J					
K					
L					
M	1.0	A3104	13	WH	
N	1.0	A3210	10	WH	
P	1.0	A3210	11	WH	
R					
S	0.75	A1503	5	WH	
T					
U	0.75	A3104	10	WH	
V	0.75	A3104	11	WH	

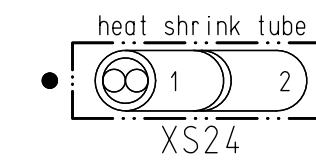
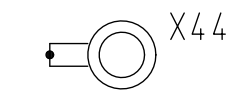
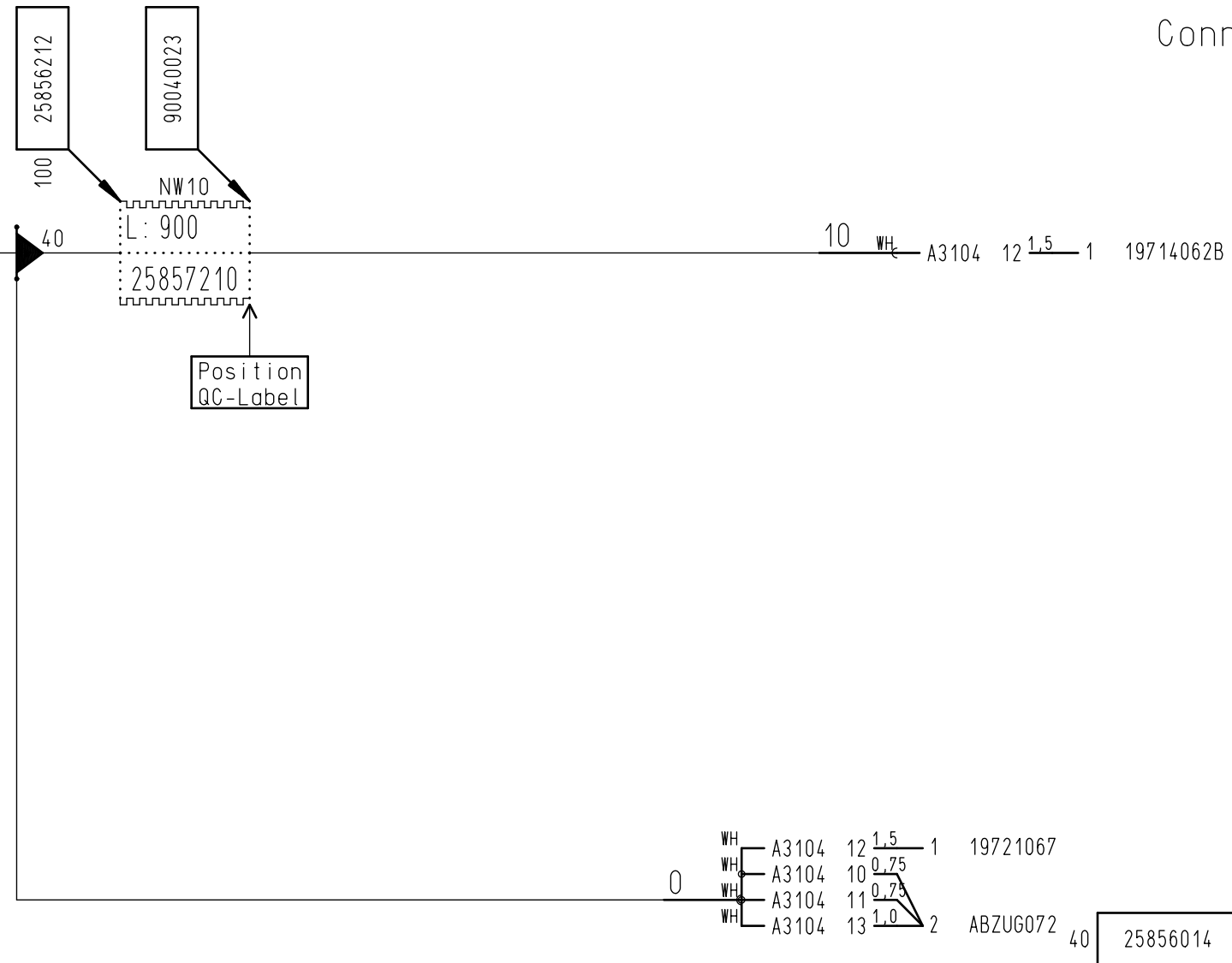

Toleranzen / tolerances	
0 - 100 mm	- 0/+10 mm
101 - 500 mm	-10/+10 mm
501 - 2000 mm	-10/+20 mm
> 2000 mm	-10/+30 mm

The tolerances are made for individual measurements and for the sum of several measurement

All housings with internal length

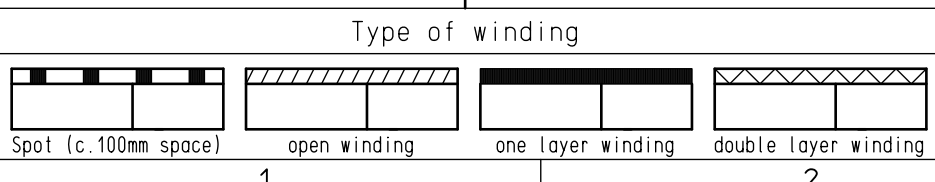

All parts have to be in conformity to IEC 60335-1/-2-72
All housings have to be labeled with device tags

1	1x	3327-00	18.07.16	DK	2015	Date	Name	Citymaster 1600	Name	Kabelbaum W11 (Kehreinheit 2. Besen)	Hako GmbH D-23840 Bad Oldesloe	Drawing Number	97133763			
A2	No.	Number appears	Change No.	Date	Name	Standard	Verified	Replacem. for same no.	Change No.	3001-67	For this drawing we reserve all rights (acc. DIN ISO 16016)	KABI 472	Type 1491	Dep. ELK	No. of Sh. 2	Sheet 1

W11

cutting list-No. : 97133763		cutting list Kabelbaum W11 (Kehreinheit 2. Besen)									
------------------------------------	--	--	--	--	--	--	--	--	--	--	--

wire	Sub	part-No. contact 1	part-No.comp.part	marking 1	wire	cr. sec.	length	colour	marking 2	part-No. contact 2	part-No.comp.part
A1503	5	19721414		X63B/E	26210310	0,75	80	WH	X63B/S	19721414	
A3104	10	19721414		X63B/U	26210310	0,75	70	WH	XS24/2	ABZUG072	
A3104	11	19721414		X63B/V	26210310	0,75	70	WH	XS24/2	^	
A3104	13	19721414		X63B/M	26210245	1,0	70	WH	XS24/2	^	
A3104	12	19714062B	25856295-L15	X44/1	26210252	1,5	870	WH	XS24/1	19721067	
A3210	10	19721414		X63B/F	26210245	1,0	80	WH	X63B/N	19721414	
A3210	11	19721414		X63B/G	26210245	1,0	80	WH	X63B/P	19721414	

1	/.	3327-00	18.07.16	DK	2016	date	name	Citymaster 1600	 Hako GmbH D-23840 Bad Oldesloe	Kabelbaum W11 (Kehreinheit 2. Besen)		
					drawn	01.04.	DK	replaced by : same no.				
					check			rev. No. : 3001-67		type : 1491	97133763	num.ofsh.:2 sheets: 2
No.	changed wire/Sub-No.	Rev.-No.	date	name								

Material: 97133763 wiring harness
 Index: 01
 Change Number: 3327-00

Material	Item	Line	Component	Object description	Material Description	Comp. Qty (CUn)	Un	Internal Comment
97133763	10	1	19714062	Ringkabelschuh ähn. DIN 46225 A6-2,5	ring term. similar DIN 46225 A6-2,5		1 PC	
97133763	10	2						Fa. Lear Nr. 25219.123.322
97133763	20	1	19721067	Stossverbinder >1-2,5 unisoliert	butt connector >1-2,5 not insulated		1 PC	
97133763	20	2						Fa. Lear Nr. 04529.321.011
97133763	30	1	19721414	ST-Kont. RT 1,6mm (0,75-1,5)	tab-cont. RT 1,6mm (0,75-1,5)		9 PC	
97133763	30	2						Fa.Amphenol Nr. SP16M1G10
97133763	40	1	19730613	Stecker für Stiftkontakt 19pol.	socket for pin contact 19-pole		1 PC	
97133763	40	2						Fa. Amphenol Nr. RT061619PNH-Ni
97133763	50	1	19730621	Endgehäuse m.Kabelverschraubung	cord grip, shell size 16		1 PC	
97133763	50	2						Fa.Amphenol Nr. RT0L-16CG-S1-Ni
97133763	60	1	19730639	Staubschutzkappe Stecker	plug dust cap		1 PC	
97133763	60	2						Fa.Amphenol Nr.RT616DCG-15-Ni
97133763	70	1	25856014	Schrumpfsch. 4,5x1-PE 3:1 trans.m.Kleber	heat shrink tube 4,5x1-PE 3:1 tran.glu		0,04 M	
97133763	70	2						Fa. Thulesius Nr. Z85527
97133763	70	3						Meterware
97133763	80	1	25856212	Schrumpfschlauch 12,7x0,6-PVC 2:1 rt	heat shrink tube 12,7x0,6-PVC 2:1 red		0,1 M	
97133763	80	2						Fa. Thulesius Nr. Z85892
97133763	90	1	25856295	Schrumpfschlauch 4,8x0,5-PVC 2:1 bl	heat shrink tube 4,8x0,5-PVC 2:1 blue		0,02 M	
97133763	90	2						Fa. Thulesius Nr. Z85877
97133763	100	1	25857210	Wellschlauch geschlossen NW10 flexibel	corrugated tube NW10		0,9 M	
97133763	100	2						LV: Stöhrmann GmbH (>&<) Co. KG 50 Meter/Lieferantengebinde (GB 20)
97133763	100	3						-
97133763	100	4						Kanban-Teil Artikelkurzauftrag vorh.
97133763	100	5						
97133763	100	6						
97133763	100	7						Fa.Reiku Nr.PARRB-10F
97133763	110	1	26210245	PVC-Fahrzeugleitung FLRY-B 1x1 weiss	PVC-automotive cable FLRY-B 1x1 white		0,23 M	
97133763	110	2						Fa. NKT Art.: AP040010BNNNNAN
97133763	110	3						
97133763	110	4						DIN 72551 / ISO6722 FLRY-B
97133763	120	1	26210252	PVC-Fahrzeugleitung FLRY-B 1x1,5 weiss	PVC-automotive cable FLRY-B 1x1,5 white		0,87 M	
97133763	120	2						Fa. NKT Art.: AP040015BNNNNAN
97133763	120	3						
97133763	120	4						DIN 72551 / ISO6722 FLRY-B
97133763	130	1	26210310	PVC-Fahrzeugleitung FLRY-B 1x0,75 weiss	PVC-automotive cable FLRY-B 1x0,75 white		0,22 M	
97133763	130	2						Fa. NKT Art.: AP040007BNNNNAN
97133763	130	3						
97133763	130	4						DIN 72551 / ISO6722 FLRY-B
97133763	140	1	28980068	Terostat 92 schwarz	sealing compound		0,1 PCD	
97133763	140	2						Fa. Henkel 310MI
97133763	140	3						Zu verarbeiten mit Reiniger 28420594
97133763	150	1	90040023	Schlüsselring 26,5x22x1,9	key ring		1 PC	